

## Integrated GMP PET Radiotracer Production and Dispensing Facility

C. Lucatelli<sup>1</sup>, D. B. Mackay<sup>1</sup>, G. Mokosa<sup>2</sup>, C. Arth<sup>2</sup>, R.C. van Ham, M.A.B. Willemsen<sup>3</sup>, J. C. Clark<sup>1</sup>

<sup>1</sup>University of Edinburgh, CRIC, <sup>2</sup> Millipore France, <sup>3</sup>Von Gahlen Nederland B.V

Dispensing of PET radiopharmaceuticals can be done either by final thermal sterilization or by sterile filtration. If thermal sterilization is the recommended method, it is very often impractical (short half-life, tracer thermo-sensitive) and many PET radiotracers are therefore dispensed by sterile filtration.

Among all the Quality Control tests required, prior to batch release, by Good Manufacturing Practice and European Pharmacopeia standards, the integrity of the membrane filter used during the final dispensing is to be checked. This activity is relatively time consuming and is the main source of analyst finger radiation doses.

To overcome this problem, we decided that this test should be automated and “in line” to avoid manual handling of this highly active filter, and to allow other activities to be performed as the filter is being tested.

The University of Edinburgh is currently setting up a brand new PET radiotracer production facility, as part of its new Clinical Research Imaging Centre (CRIC) and wants to achieve a state of the art uncluttered integrated facility.

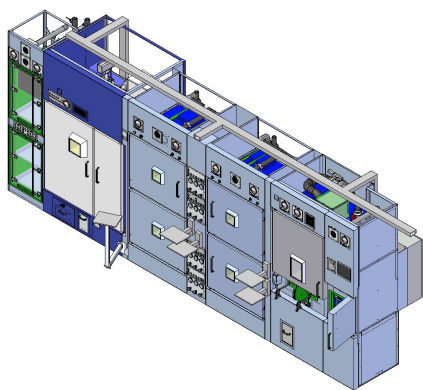

**Figure 1:** GMP production lab hot cells assembly. From left to right: ventilated HPLC cabinet; GE FASTLab dispenser and sterilizer; 2 VG SB2S hot cells; 2 VG SB2S hot cells; VG Grade A DPB-LF dispenser.



**Figure 2:** Millipore Integritest® 4

This facility will operate a GE PETtrace 8 cyclotron equipped with 5 targets: 2 Niobium for <sup>18</sup>F production, 1 <sup>11</sup>C-CO<sub>2</sub>, 1 <sup>11</sup>C-CH<sub>4</sub> and 1 <sup>15</sup>O-target. The 4 first targets will be connected to 2 independent labs, a GMP production housing 4 hot cells and a R&D lab housing 3 hot cells. The target will be routed to the right destination using a specially designed Activity Delivery System. A specially designed ventilated HPLC cabinet, integrated within the row of hot cells will house 2 GE

synthesiser module electronic racks, 2 semi-preparative HPLC pumps and a computer controlling the cyclotron.

In addition to the 4 production hot cells, the GMP production lab will be equipped with 2 dispenser hot cells, a GE FASTLab dispenser and autoclave for thermal sterilisation and a Grade A Von Gahlen DPB-LF hot cell for the aseptic dispensing of radiotracers sensitive to heat or with a short half-life. Each of the production hot cells will be connected via shielded ducts to both dispensers.

As part of the design of the lab, we investigated the possibility of integrating a filter integrity test facility into our aseptic dispensing hot cell.

We decided to use the “off the shelf” Millipore Integritest 4 (Networked version) as a basis for this system, due to its modular design. We worked jointly with Millipore and Von Gahlen to achieve a solution which would allow the filter to be directly and automatically tested as part of the dispensing process.

The challenge was to integrate this tabletop system into the hot cell without compromising the Grade A laminar flow and the radioprotection. To achieve this integration, the commercial system needed to be disassembled. The touch screen computer panel is located on the front face of the hot cell. The part connected to the filter (External Valve Array) is fitted into the shielded environment and the remaining parts are located in a shielded enclosure on the top of the hot cell. A solenoid valve protects the Millipore External Valve Array during the filtration of the product. The filter is connected to product transfer line and to the Millipore Integritest® 4 by a sterile single use Vygon tubing assembly equipped with a check valve.

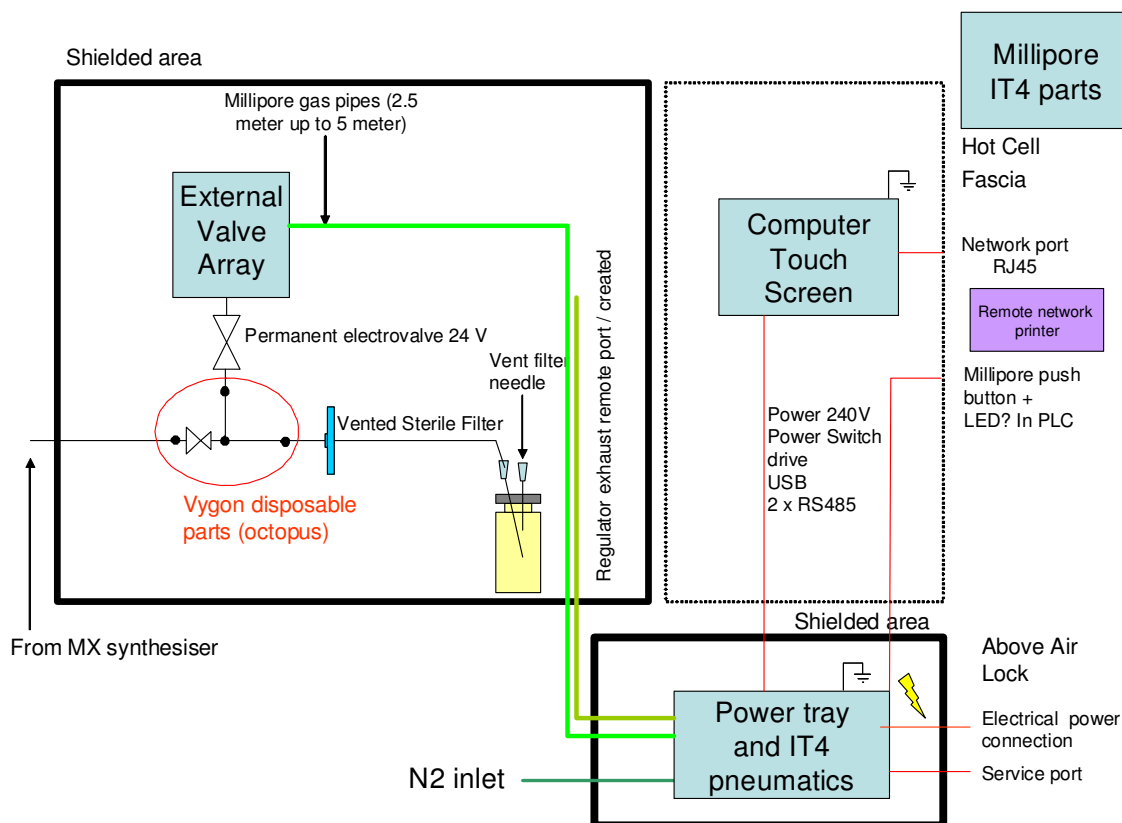

**Figure 3:** Integration of the Millipore Integritest®4 into the Von Gahlen DPB-LF hot cell.